

FS-FROST Insert compatible with Frosthaven® Assembly Instructions



The package contains 13 sheets: three double and seven single sheets.

After assembly the trays are put in up to five layers in the original game box.

Ordinary PVA glue is required when assembling each tray.

Please make sure you dry-assemble each tray correctly before gluing it together.

Please check www.foldedspace.net for general assembly tips and product images.

FS-FROST

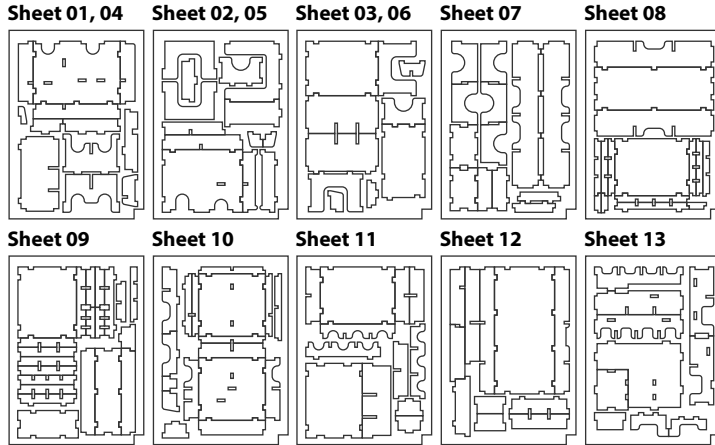
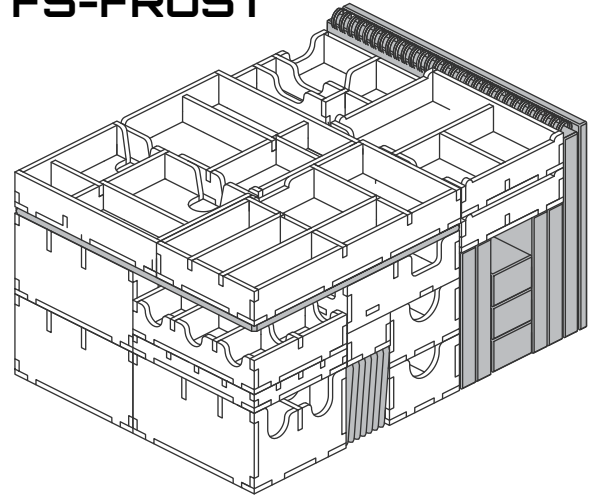

Tray 1

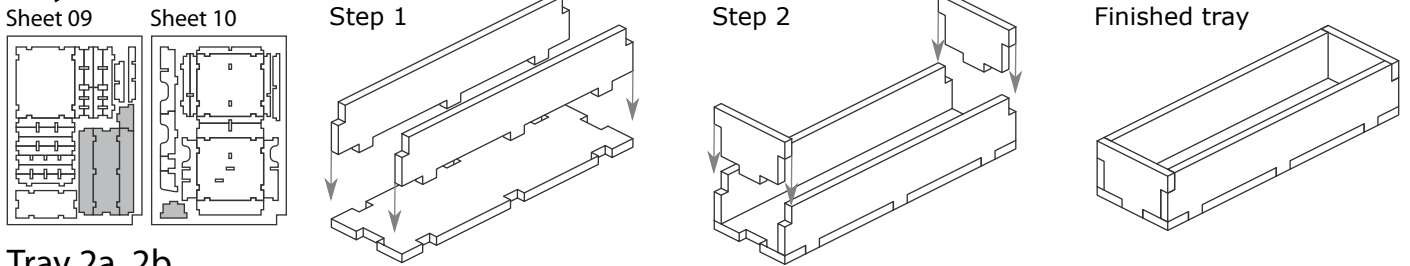

Tray 2a, 2b

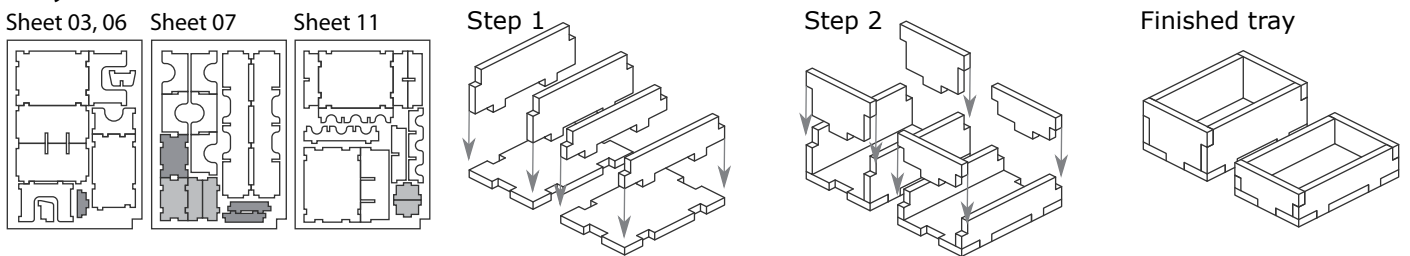

Tray 3

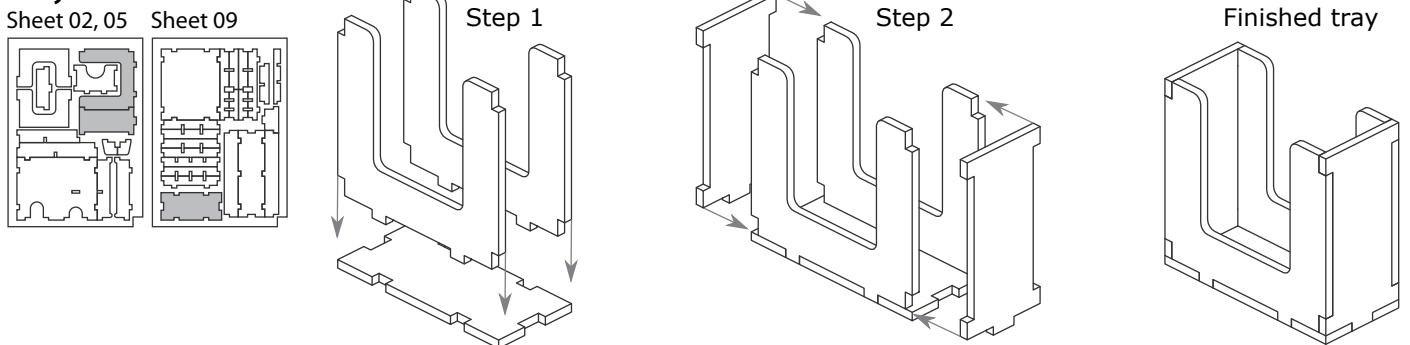

Tray 4a, 4b (the trays are identical)

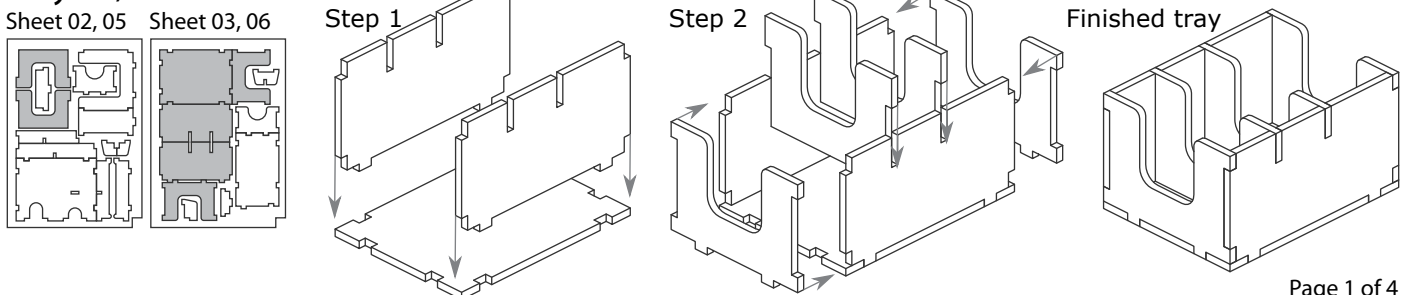

Tray 5

Sheet 02, 05 Sheet 07

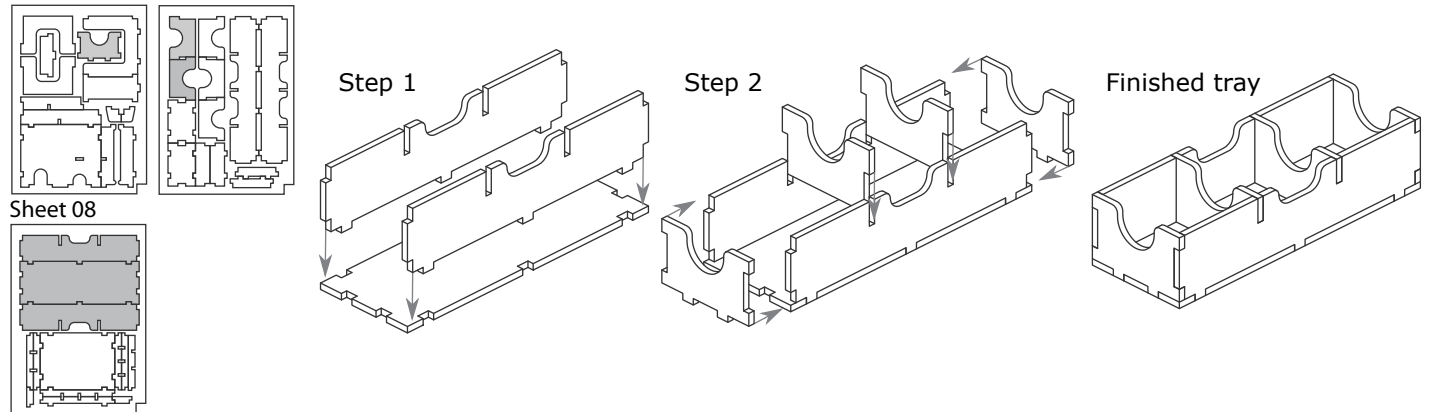

Tray 6

Sheet 03, 06 Sheet 07

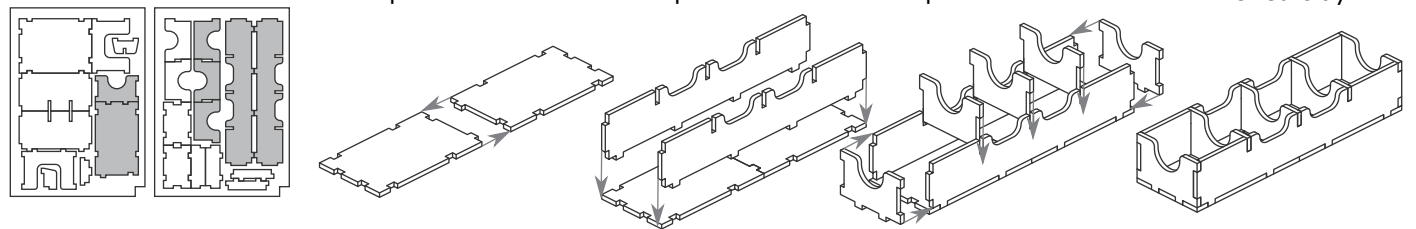

Tray 7

Sheet 01, 04 Sheet 11

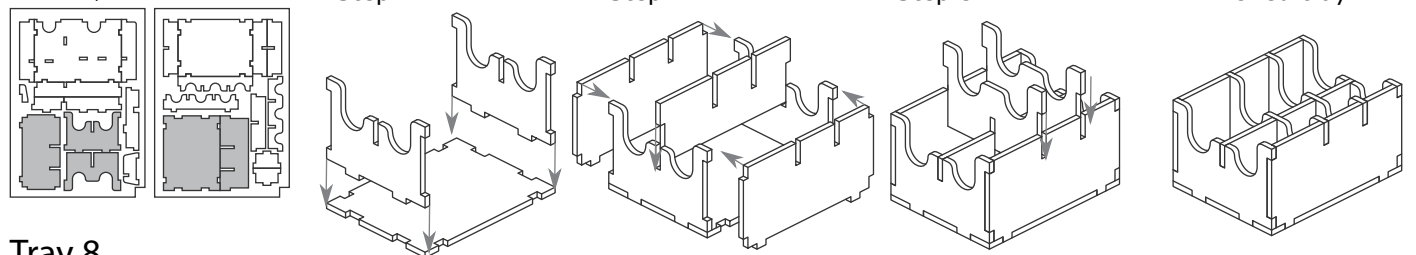

Tray 8

Sheet 11

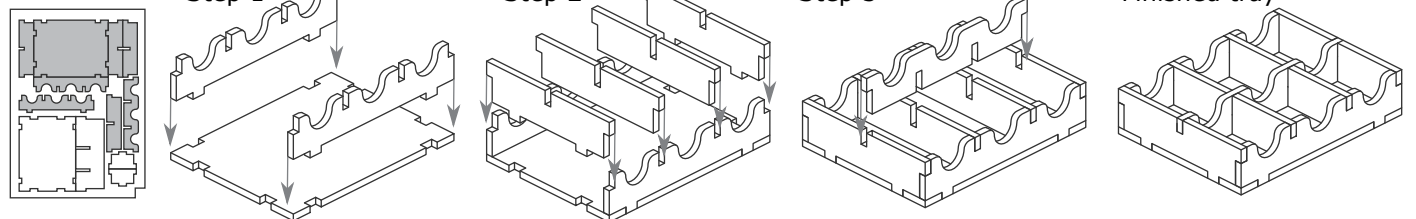

Tray 9

Sheet 10

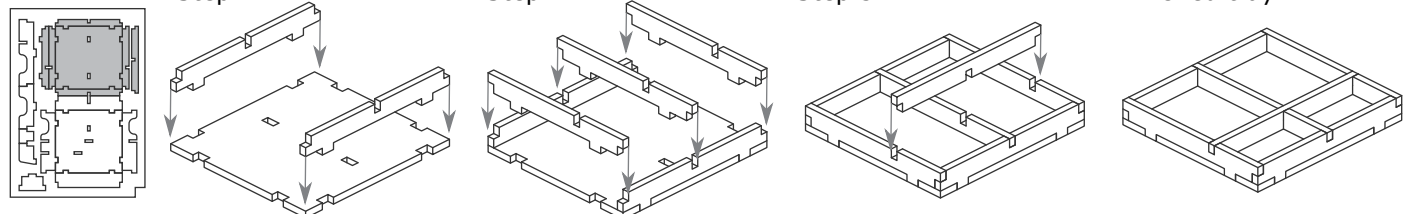

Tray 10

Sheet 08 Sheet 09

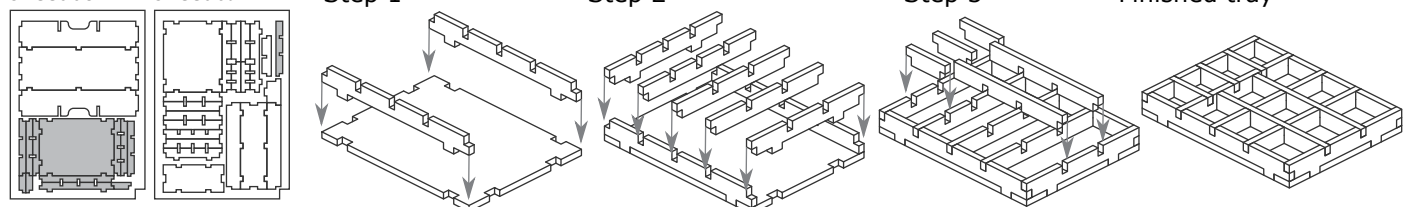

Tray 11

Sheet 09

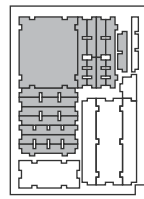

Step 1

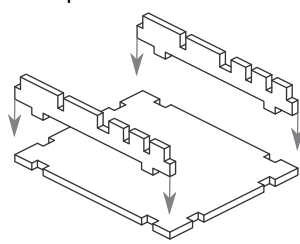

Step 2

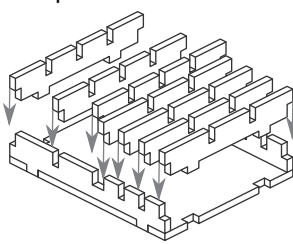

Step 3

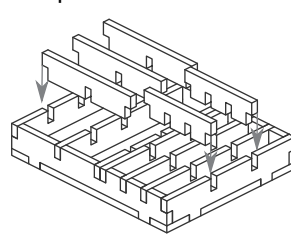

Finished tray

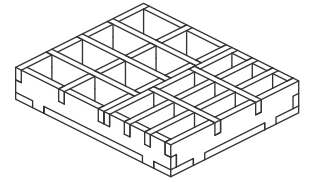

Tray 12

Sheet 10

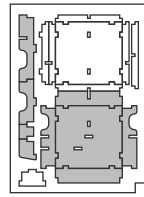

Step 1

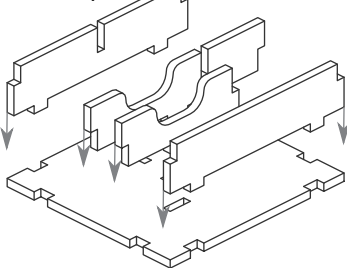

Step 2

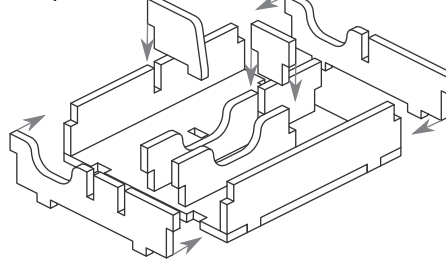

Finished tray

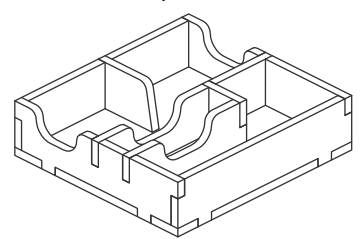

Tray 13

Sheet 12

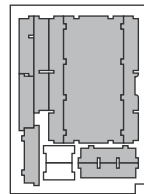

Step 1

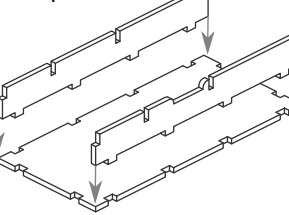

Step 2

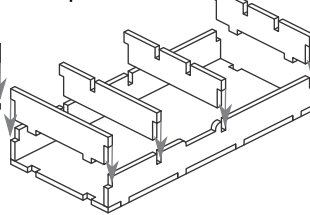

Step 3

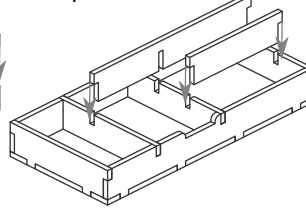

Finished tray

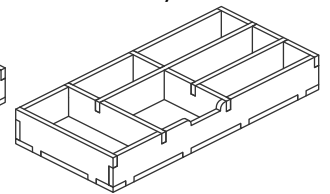

Tray 14a, 14b

(the trays are identical)

Sheet 02, 05

Sheet 03, 06

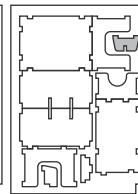
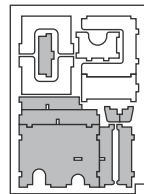

Step 1

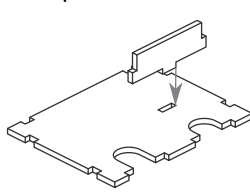

Step 2

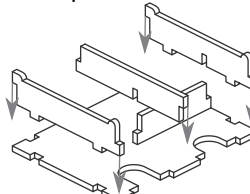

Step 3

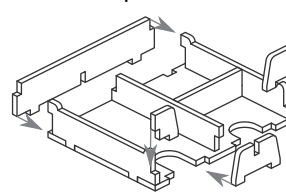

Finished tray

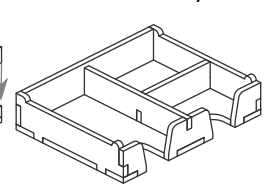

Tray 15a, 15b

(the trays are identical)

Sheet 01, 04

Sheet 03, 06

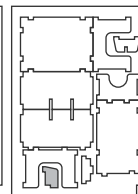
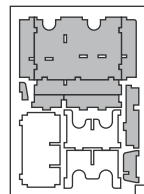

Step 1

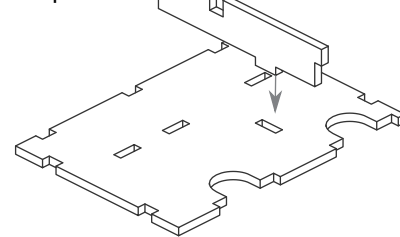

Step 2

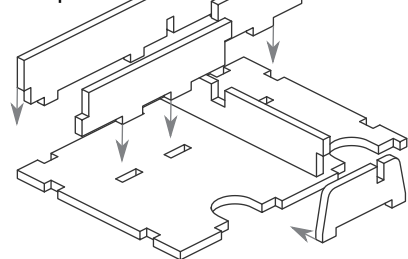

Step 3

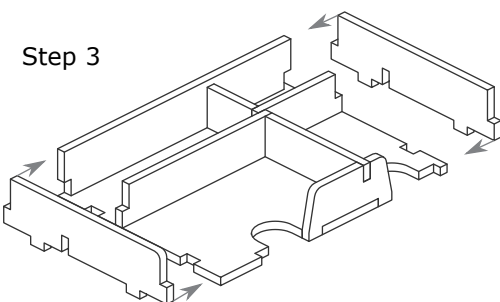

Step 4

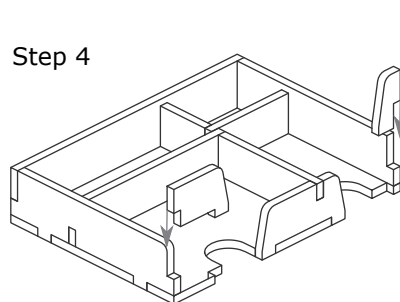

Finished tray

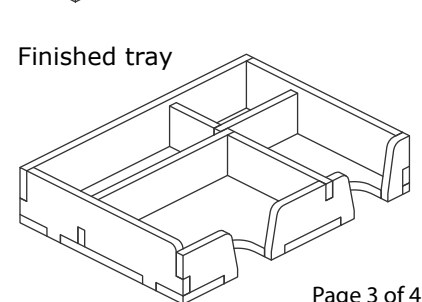

Tray 16

Sheet 12

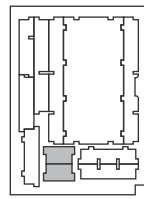

Sheet 13

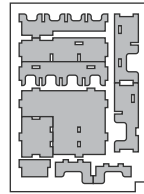

Step 1

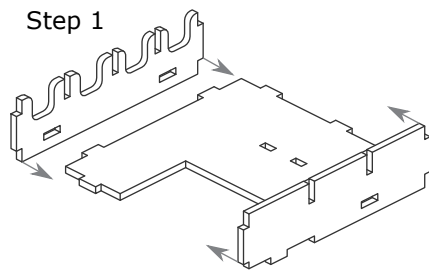

Step 2

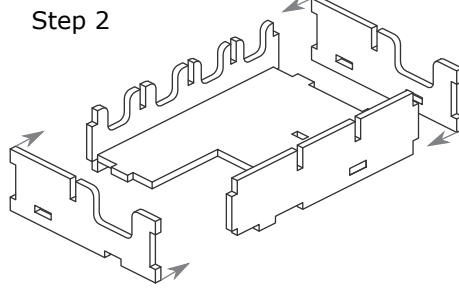

Step 3

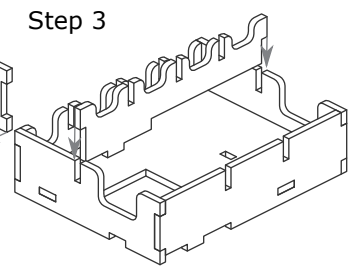

Step 4

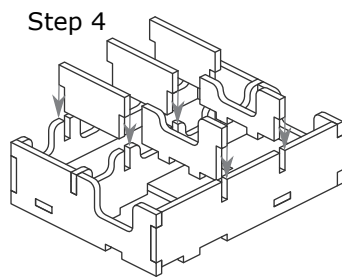

Step 5

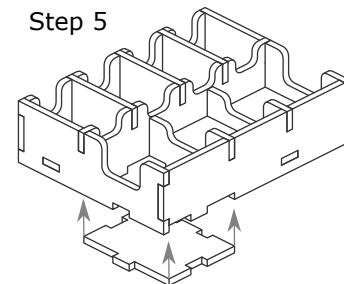

Finished tray

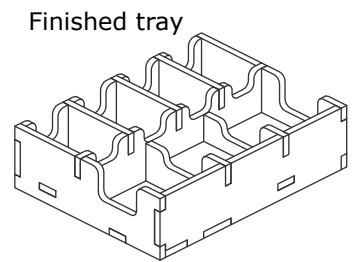

FS-FROST

Trays 15a, 15b & 13

Trays 9, 12

Trays 14a, 14b

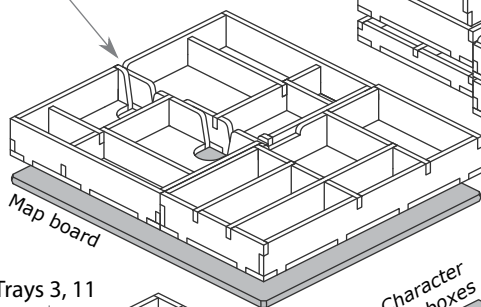

Trays 3, 11

Trays 2a, 2b

Character tuck boxes

Rule & Scenario books

Tray 16

Miniature tuck boxes

Trays 4a, 4b

Trays 7, 10, 8

Envelopes, Tray 1

Trays 5, 6

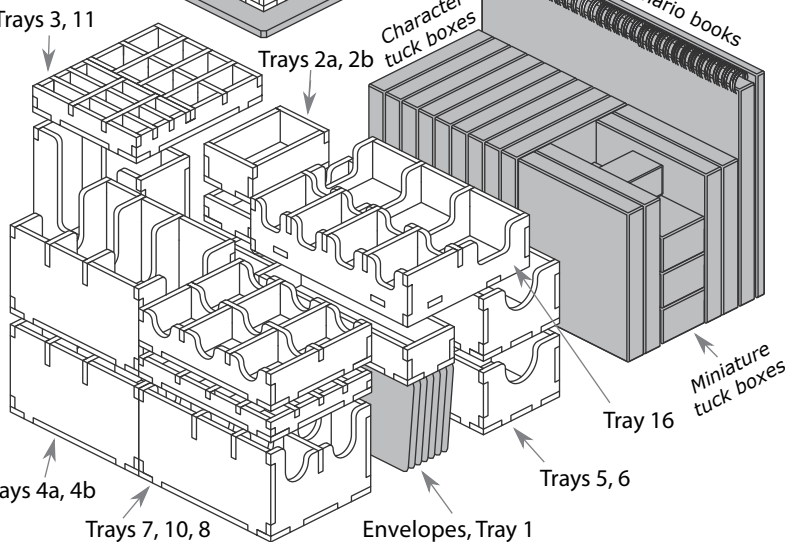

Tray legend (using player trays):

- Tray 1 - plastic bases
- Tray 2a, b - loot tokens, and scenario aid tokens
- Tray 3 - boss & monster stat cards and stat sleeves
- Tray 4a - building, summer road and summer outpost decks
- Tray 4b - monster & dungeon randomizer, winter road and winter outpost decks
- Tray 5, 6 - monster ability cards, and item cards
- Tray 7 - challenge & random scenario, town guard, battle goal, loot, and attack modifier decks
- Tray 8 - medium monster standees
- Tray 9 - damage and element board tokens
- Tray 10 - condition tokens
- Tray 11 - small monster standees
- Tray 12 - large monster standees and four character mini tuck boxes
- Tray 13 - map overlay tiles and monster initiative tokens
- Tray 14a, b, & 15a, b - player trays
- Tray 16 - map overlay tiles

Note: Tray 12 has space for up to four character mini tuck boxes. these can be three smaller boxes and one larger. Should your party of mercenaries be larger than this, some of the boxes will need to be stored with the other tuck boxes.

Note also that when using the four player trays there is no space in the box for the game map tiles. These should be stored separately, preferably in the Folded Space map folder product, FS-FHMAP.

FS-FROST Layout without player trays:

The insert can also be used with the game map tiles inside the game box, added on top of the insert trays. In order to provide extra volume for the tiles the four player trays need to be removed.

Four of the smaller character tuck boxes need to be stored as shown in the layout on the right-hand side, that is on top of the other tuck boxes. The smaller map tiles can then be placed on top of the map board, and the larger tiles on top of them. Please check our website www.foldedspace.com for photos of this layout variant.

