

Assembly Instructions

The package contains 4 sheets: one double and two single sheets.
 After assembly the trays are put in up to two layers in the original game box.
 Ordinary PVA glue is required when assembling each tray.
 Please make sure you dry-assemble each tray correctly before gluing it together.
 Please check www.foldedspace.com for general assembly tips.

FS-NON

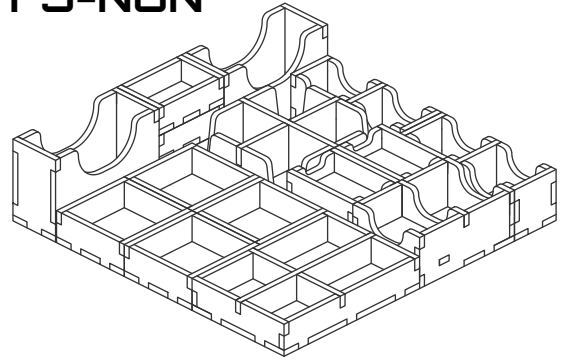

Sheet A1, A2

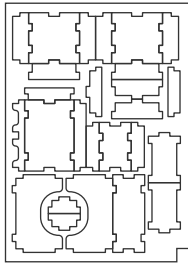

Sheet B

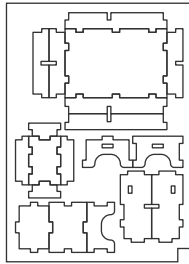

Sheet C

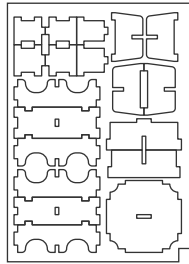

Tray 1a, 1b, 1c

(the trays are identical)

Sheet A1, A2 Sheet B

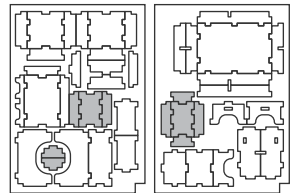

Step 1

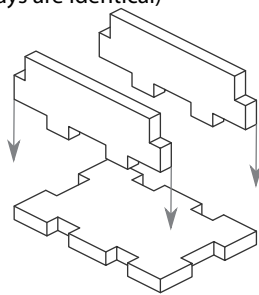

Step 2

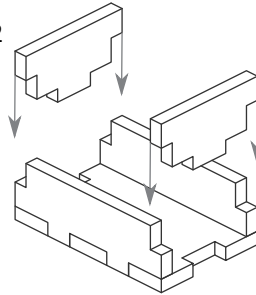

Finished tray

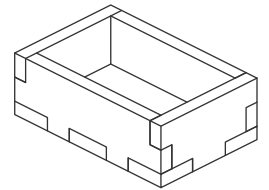

Tray 2a, 2b, 2c, 2d

(the trays are identical)

Sheet A1, A2

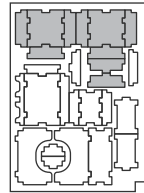

Step 1

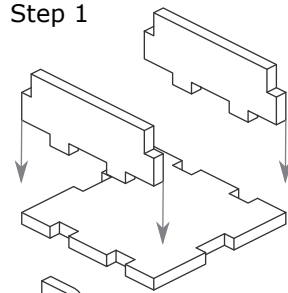

Step 2

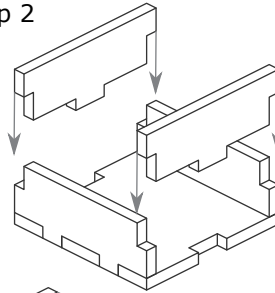

Finished tray

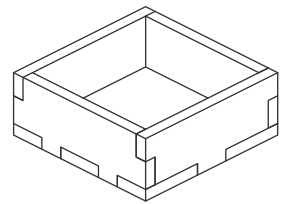

Tray 3a, 3b

(the trays are identical)

Sheet A1, A2

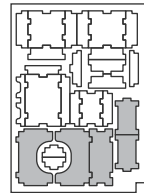

Step 1

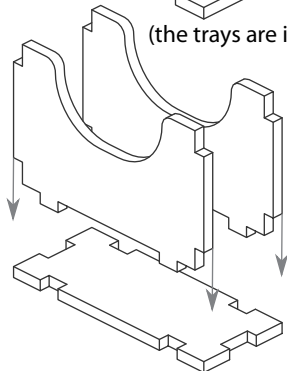

Step 2

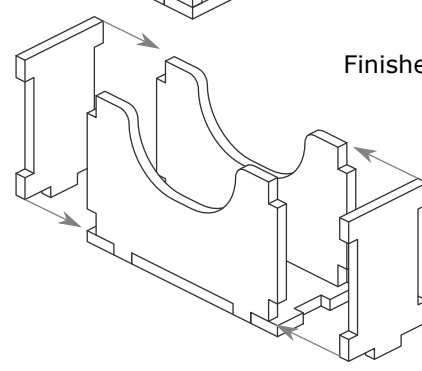

Finished tray

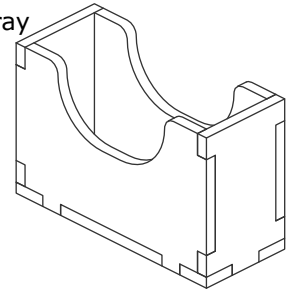

Tray 4a, 4b

Sheet A1, A2

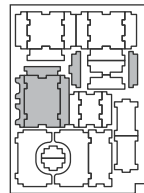

Step 1

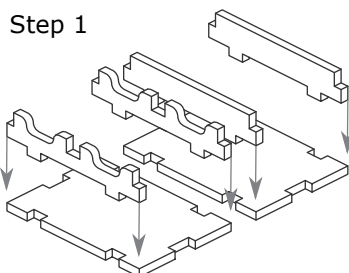

Step 2

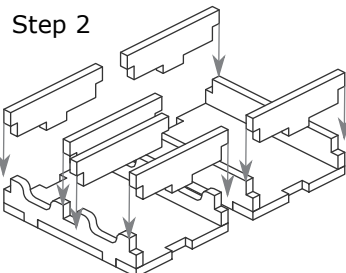

Finished trays

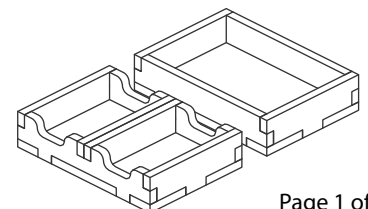

Tray 5a, 5b

Sheet C

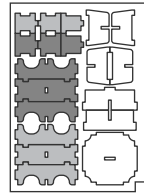

Step 1

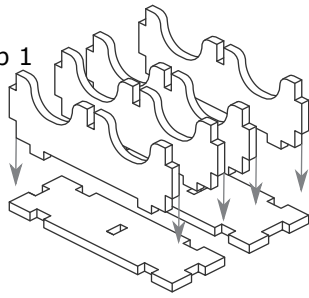

Step 2

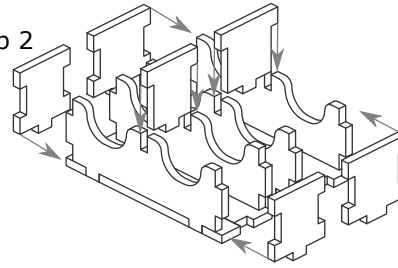

Finished trays

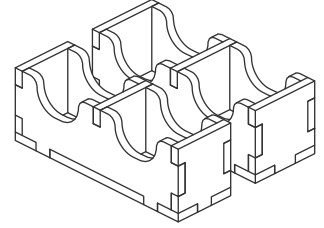

Tray 6

Sheet B

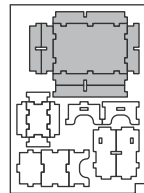

Step 1

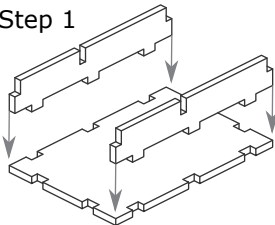

Step 2

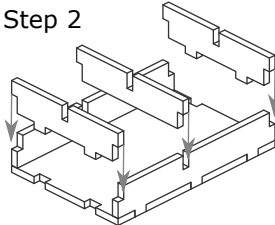

Step 3

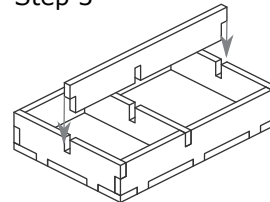

Finished tray

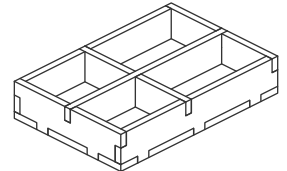

Tray 7

Sheet C

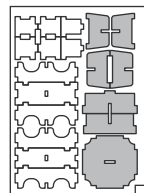

Step 1

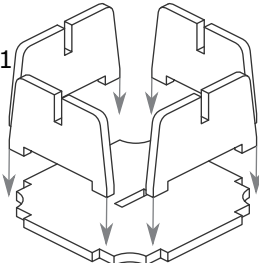

Step 2

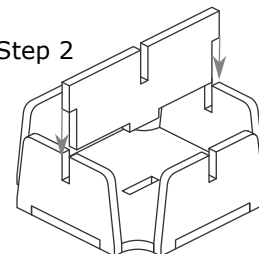

Step 3

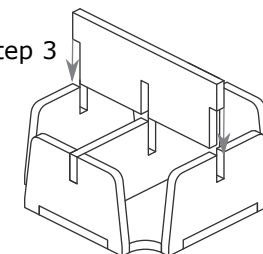

Finished tray

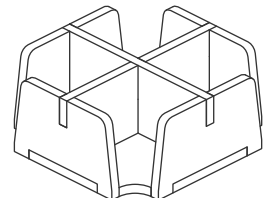

Tray 8

Sheet B

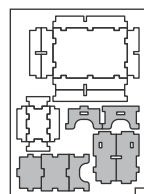

Step 1

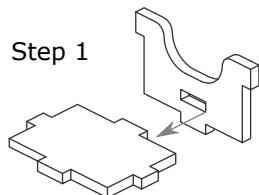

Step 3

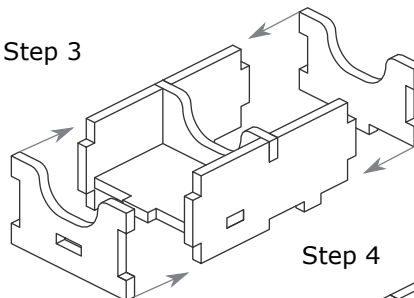

Finished tray

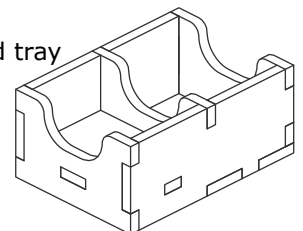

Step 2

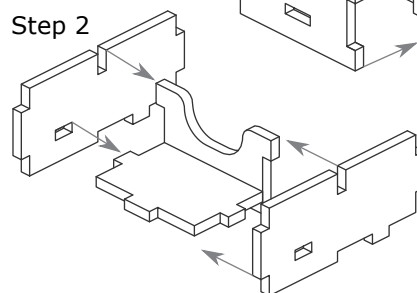

Step 4

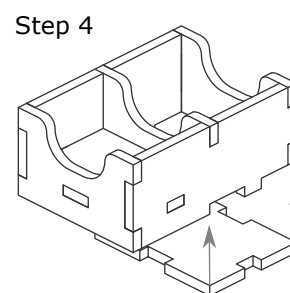

FS-NON

Tray 1a, 1b, 1c

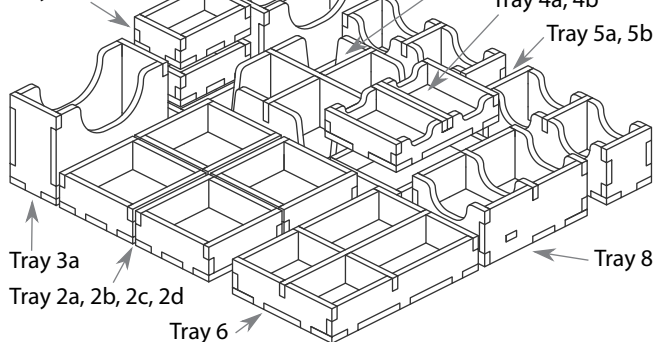

Tray 3b

Tray 7

Tray 4a, 4b

Tray 5a, 5b

Tray 3a

Tray 2a, 2b, 2c, 2d

Tray 6

Tray 8

Please check www.foldedspace.com for photos of this insert in use.

Tray legend:

- Tray 1a, b, c - order tokens, search tokens, and other tokens
- Tray 2a, b, c, d - player pieces
- Tray 3a, b - cards, random locations and 1st player token
- Tray 4a - villagers
- Tray 4b - story mode tokens: giant boar, specialist, guild tank, items, ship, and villager tokens
- Tray 5a - rifts, mystic healer and story mode enemies
- Tray 5b - enemies
- Tray 6 - coins and experience tokens
- Tray 7 - building tiles
- Tray 8 - gear and specialists